

CH-II可変側溝(中国地域限定)

CADデータ

標準品 T-25 縦断走行用 内幅300~600

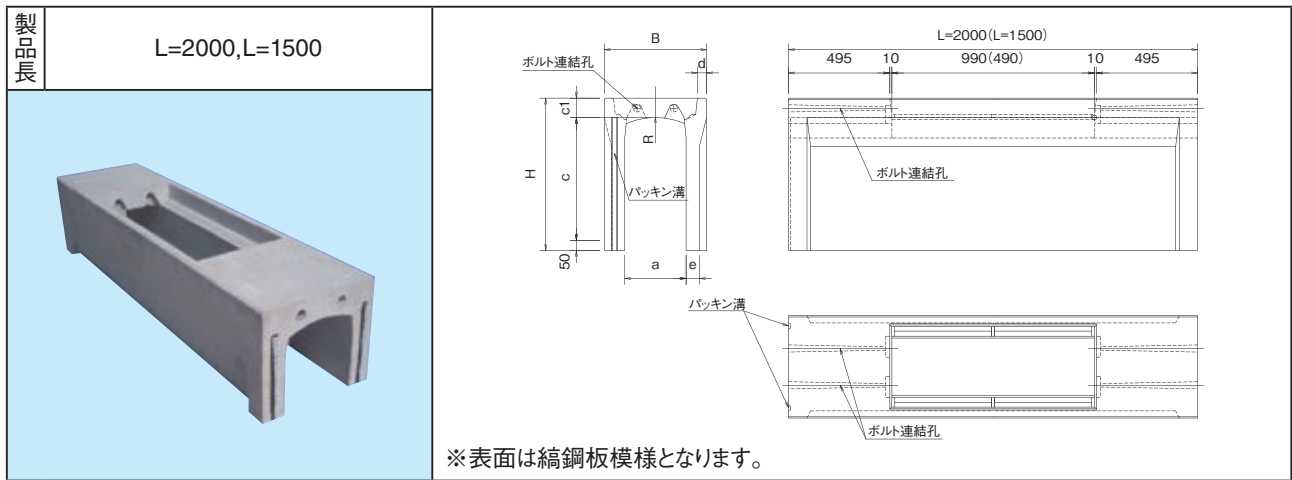

| 呼び名 (幅ax高c) | 各部の寸法(mm) | | | | | | 参考質量(kg) | |
|----------------|-----------|------|-----|----|----|-----|----------|--------|
| | B | H | c1 | d | e | R | L=2000 | L=1500 |
| 300 | 300 | 445 | | | | | 360 | 300 |
| | 400 | 545 | | | 55 | | 415 | 340 |
| | 500 | 645 | | | | | 475 | 385 |
| | 600 | 745 | | | | | 575 | 460 |
| | 700 | 845 | 95 | 45 | 65 | 360 | 640 | 510 |
| | 800 | 945 | | | | | 710 | 565 |
| 400 | 900 | 1045 | | | | | 885 | 695 |
| | 1000 | 1145 | | | 80 | | 965 | 755 |
| | 1100 | 1245 | | | | | 1045 | 815 |
| | 400 | 560 | | | | | 500 | 415 |
| | 500 | 660 | | | 60 | | 560 | 460 |
| | 600 | 760 | | | | | 615 | 500 |
| 400 | 700 | 860 | | | | | 735 | 595 |
| | 800 | 960 | 110 | 50 | 70 | 470 | 810 | 650 |
| | 900 | 1060 | | | | | 880 | 705 |
| | 1000 | 1160 | | | | | 1070 | 845 |
| | 1100 | 1260 | | | 85 | | 1155 | 915 |
| | 1200 | 1360 | | | | | 1245 | 975 |

| 呼び名 (幅ax高c) | 各部の寸法(mm) | | | | | | 参考質量(kg) | |
|----------------|-----------|------|-----|----|-----|-----|----------|--------|
| | B | H | c1 | d | e | R | L=2000 | L=1500 |
| 500 | 400 | 575 | | | | | 560 | 510 |
| | 500 | 675 | | | 55 | | 620 | 565 |
| | 600 | 775 | | | | | 720 | 615 |
| | 700 | 875 | | | 65 | | 790 | 670 |
| | 800 | 975 | | | | | 860 | 725 |
| | 900 | 1075 | 125 | 55 | | 600 | 1030 | 910 |
| 600 | 1000 | 1175 | | | 80 | | 1115 | 980 |
| | 1100 | 1275 | | | | | 1195 | 1055 |
| | 1200 | 1375 | | | | | 1420 | 1120 |
| | 1300 | 1475 | | | 95 | | 1520 | 1195 |
| | 1400 | 1575 | | | | | 1615 | 1270 |
| | 400 | 590 | | | | | 665 | 605 |
| 600 | 500 | 690 | | | 60 | | 725 | 660 |
| | 600 | 790 | | | | | 790 | 715 |
| | 700 | 890 | | | | | 905 | 775 |
| | 800 | 990 | | | 70 | | 980 | 835 |
| | 900 | 1090 | 140 | 60 | | 730 | 1050 | 890 |
| | 1000 | 1190 | | | | | 1240 | 1095 |
| 600 | 1100 | 1290 | | | 85 | | 1330 | 1170 |
| | 1200 | 1390 | | | | | 1420 | 1245 |
| | 1300 | 1490 | | | | | 1665 | 1320 |
| | 1400 | 1590 | | | 100 | | 1760 | 1395 |
| | 1500 | 1690 | | | | | 1870 | 1485 |